

# ULCO 132

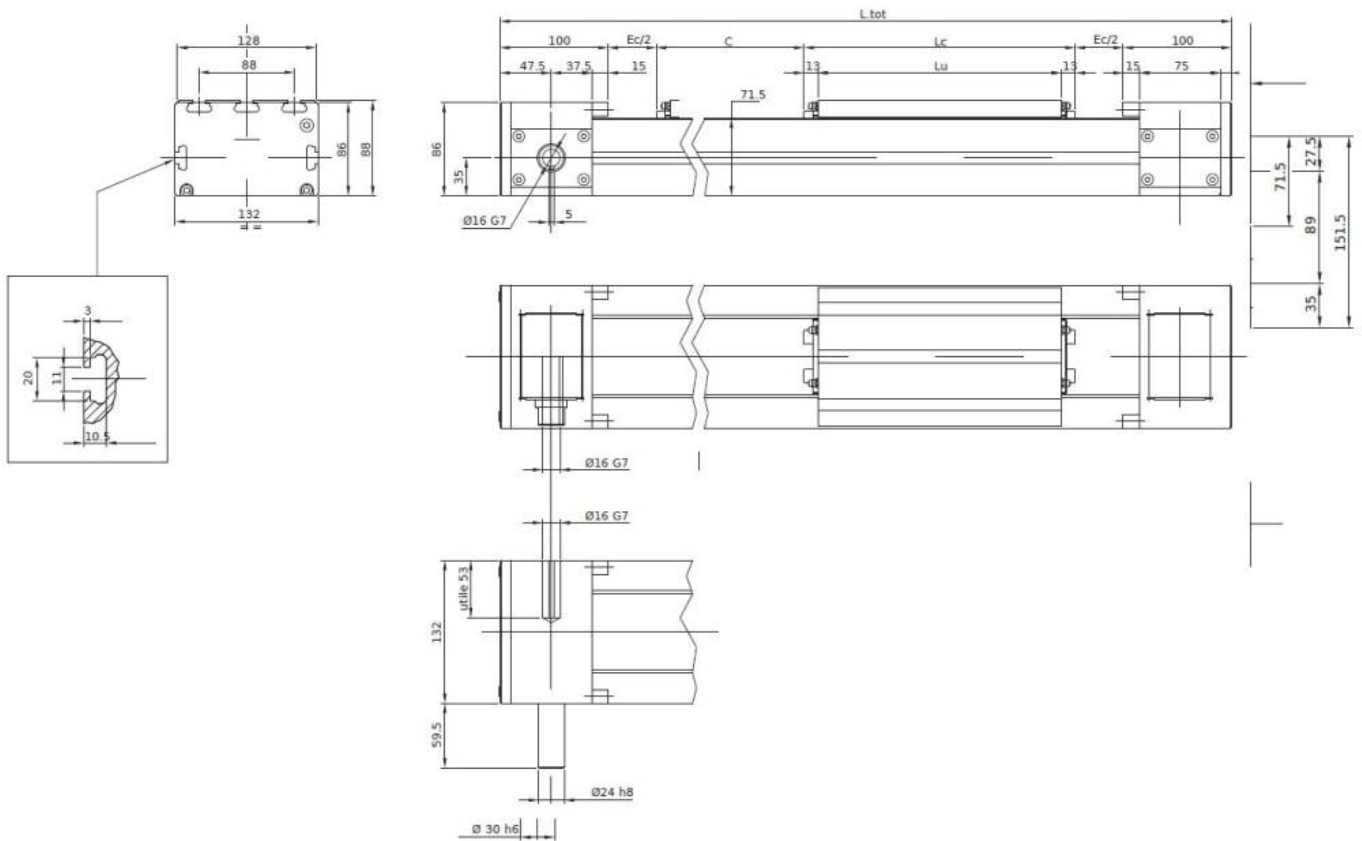

## Mechanical Drawing



## Load rating

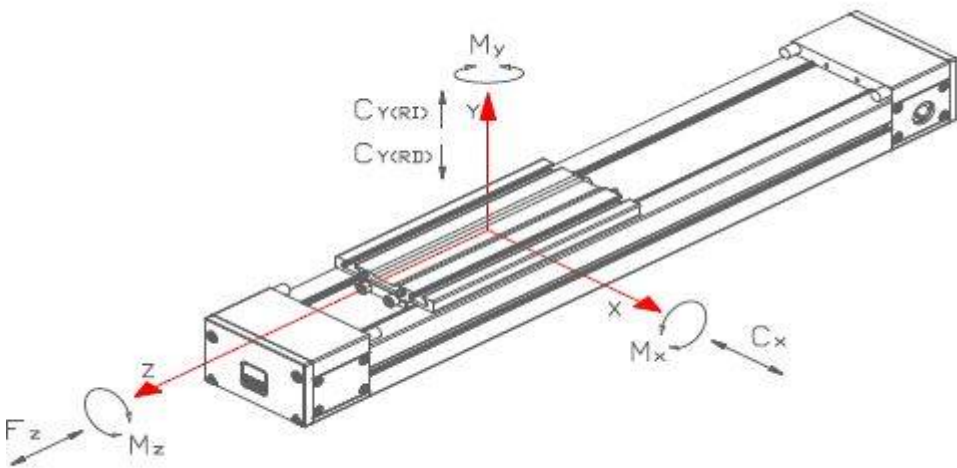

<b>F<sub>z</sub></b> [daN]	<b>C<sub>x</sub></b> [daN]	<b>C<sub>y</sub></b> [daN] (*)	<b>C<sub>ox</sub></b> [daN]	<b>C<sub>oy</sub></b> [daN] (*)	<b>M<sub>ox</sub></b> [daNm]	<b>M<sub>oy</sub></b> [daNm]	<b>M<sub>oz</sub></b> [daNm]
<b>360</b>	<b>5053</b>	<b>5053↓</b> <b>5053↑</b>	<b>8710</b>	<b>8710↓</b> <b>8710↑</b>	<b>910</b>	<b>910</b>	<b>220</b>

## Technical data

Parameter	Symbol	Value	Unit
Max usable stroke		6500	mm
Total lenght	Ltot	C+Lc+260	mm
Carriage length	Lc	290	mm
Carriage usable length	Lu	270	mm
Extra-stroke (safety)	Ec	60	mm
Max speed		180	m/min
Max acceleration		100	m/sec <sup>2</sup>
Position repeatability		< 0.05	mm
Aluminium profile section		132 x 71 x 5	mm
Inertia momentum of aluminium profile	Ix	1413267	mm <sup>4</sup>
Inertia momentum of aluminium profile	Iy	2429437	mm <sup>4</sup>
Type of mechanic		linear guide with compact block	
Belt type		Poliuretán HTD-5M-75	
Pulley teeth number		36	
Diameter		57,3	mm
Linear movement per rotation		180	mm
Operating temperature		-20 / +60	degrees

From:

<https://www.nilab.at/dokuwiki/> - **NiLAB GmbH**  
**Knowledgebase**

Permanent link:

[https://www.nilab.at/dokuwiki/doku.php?id=ulco:ulco\\_132](https://www.nilab.at/dokuwiki/doku.php?id=ulco:ulco_132)

Last update: **2025/07/24 13:40**

