

Probe function

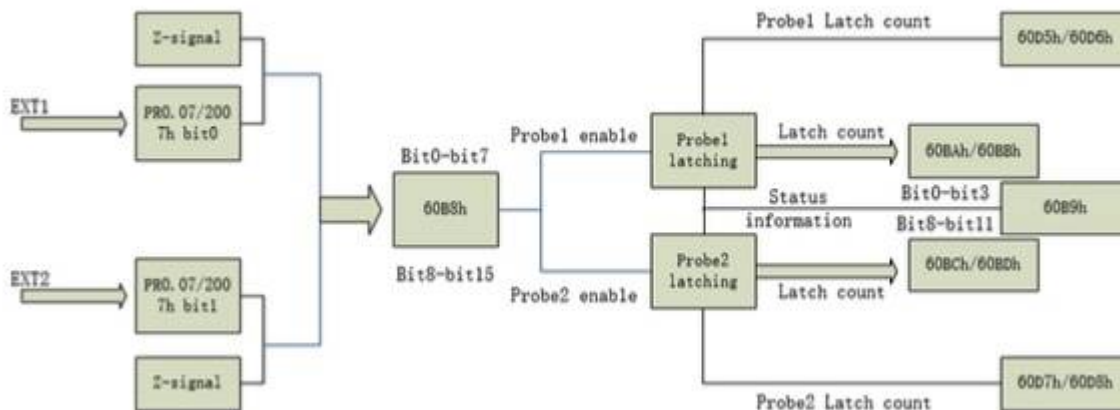

When using EXT1 or EXT2 as probe, please set as following:

a) Set polarity of EXT 1 or EXT 2 as probe. Set the level polarity of the probes using 0x2007 / Pr0.07. Bit 0 for EXT1 signal, bit 1 for EXT2 signal

b) Probe function is set through 0x60B8 (Bit 0-7 is for probe 1, bit8-15 is for probe 2). Functions including activation trigger signal selection, triggering mode and triggering signal edge.

Please take note:

i) Triggering mode: Single trigger, rising signal edge = valid; triggering mode:

Continuous trigger, rising and falling edge = valid

ii) After activation, trigger signal selection, triggering signal edge settings, counter will be reset and 0x60B9 status will change as well.

iii) Probe signal level is shown in 60FD: EXT1 → bit 26, EXT2 → bit 27.

Relevant objects

Index	Sub Index	Label	Access	Data Type	Units	Range	Default
2007h	00h	Probe 1 polarity setting	RW	Uint16		0~0xFFFF	1
2007h	01h	Probe 2 polarity setting	RW	Uint16		0~0xFFFF	1
60B8h	00h	Probe control word	RW	Uint16		0~65535	0
60B9h	00h	Probe status word	RO	Uint16		0~65535	0
60BAh	00h	Probe 1or Z-signal rising edge latching position	RO	int32	Command unit	-2147483648~2147483647	0
60BBh	00h	Probe 1 or Z-signal falling edge latching position	RO	int32	Command unit	-2147483648~2147483647	0
60BCh	00h	Probe 2 or Z-signal rising edge latching position	RO	int32	Command unit	-2147483648~2147483647	0
60BDh	00h	Probe 2 or Z-signal falling edge latching position	RO	int32	Command unit	-2147483648~2147483647	0
60D5h	00h	Probe 1 or Z-signal rising edge counter	RO	Uint32		0~4294967296	0
60D6h	00h	Probe 1 or Z-signal falling edge counter	RO	Uint32		0~4294967296	0
60D7h	00h	Probe 2 or Z-signal rising edge counter	RO	Uint32		0~4294967296	0
60D8h	00h	Probe 2 or Z-signal falling edge counter	RO	Uint32		0~4294967296	0

Signal input of EXT1 and EXT2

EXT1 Pin1 and Pin5 of CN1 terminal

EXT2 Pin2 and Pin6 of CN1 terminal

Probe control Word 60B8h

Bit	Definition	Details
0	Probe 1 enable	0--Disable 1--Enable
1	Probe 1 mode	0--Single trigger mode 1--Continuous trigger mode
2	Probe 1 trigger signal selection	0--EXT1 signal 1--Z signal
3	Reserved	-
4	Probe 1 rising edge trigger	0--Disable 1--Enable

5	Probe 1 falling edge trigger	0--Disable 1--Enable
6-7	Reserved	-
8	Probe 2 enable	0--Disable 1--Enable
9	Probe 2 mode	0--Single trigger mode 1--Continuous trigger mode
10	Probe 2 trigger signal selection	0--EXT2 signal 1--Z signal
11	Reserved	-
12	Probe 2 rising edge trigger	0--Disable 1--Enable
13	Probe 2 falling edge trigger	0--Disable 1--Enable
14-15	Reserved	-

Probe Status Word 60B9h

Bit	Definition	Details
0	Probe 1 enable	0--Disable 1--Enable
1	Probe 1 or Z-signal rising edge trigger	0-- not executed 1-- executed
2	Probe 1 or Z-signal falling edge trigger	0-- not executed 1-- executed
3-5	Reserved	-
6-7	Reserved	-
8	Probe 2 enable	0--Disable 1--Enable
9	Probe 2 or Z-signal rising edge trigger	0-- not executed 1-- executed
10	Probe 2 or Z-signal falling edge trigger	0-- not executed 1-- executed
11-13	Reserved	-
14-15	Reserved	-

Latch Position Register

Index	Details
60BAh	Probe 1 or Z-signal rising edge latch position
60BBh	Probe 1 or Z-signal falling edge latch position
60BCh	Probe 2 or Z-signal rising edge latch position
60BDh	Probe 2 or Z-signal falling edge latch position

Latch Counter Register

Index	Details
60D5h	Probe 1 or Z-signal rising edge counter
60D6h	Probe 1 or Z-signal falling edge counter
60D7h	Probe 2 or Z-signal rising edge counter
60D8h	Probe 2 or Z-signal falling edge counter

Probe mode

Set bit1/bit9 of 60B8h (Probe mode), 0 = Single trigger mode, 1 = Continuous trigger mode.

1 Single trigger mode

Triggers only when the trigger signal is valid for the first time. In order to latch the position, users need to set bit0/bit8 of 60B8h to 0, then set bit0/bit8 of 60B8h to 1. The sequence diagram is as shown below:

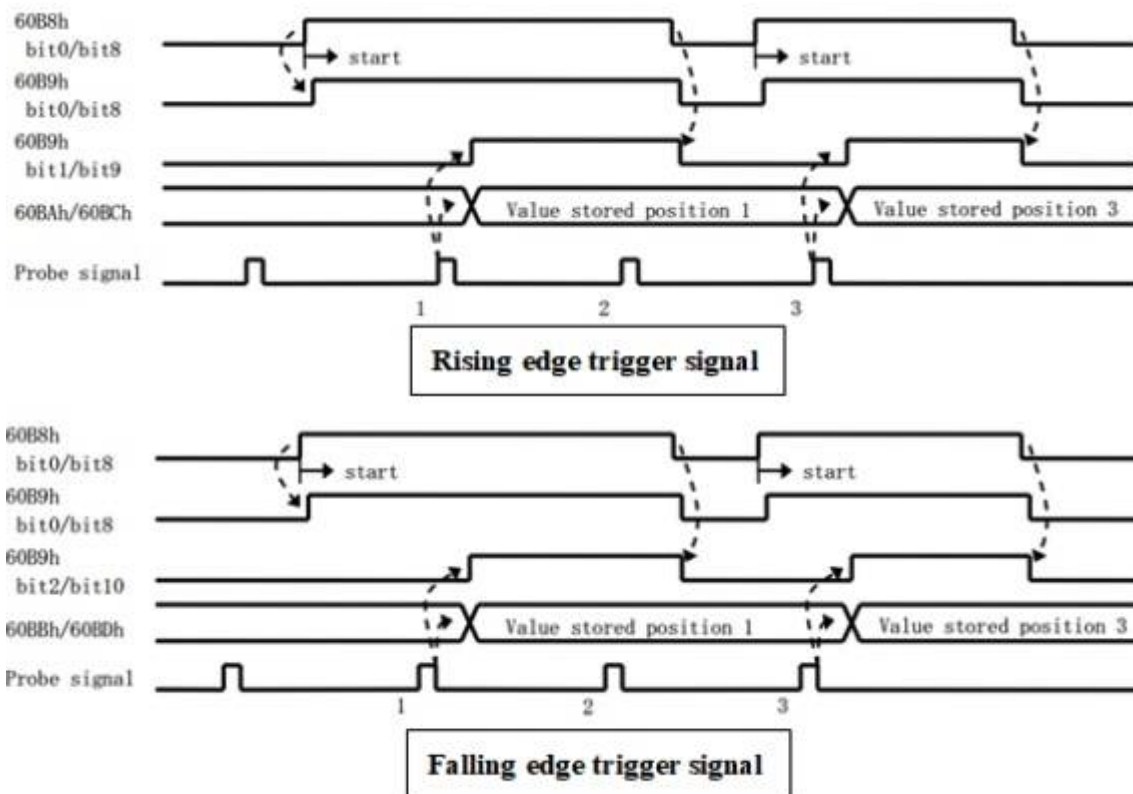

2 Continuous trigger mode

The data saved from signal triggering will be saved until the next trigger signal. Enabling the probe again is not needed. Sequence diagram as shown below:

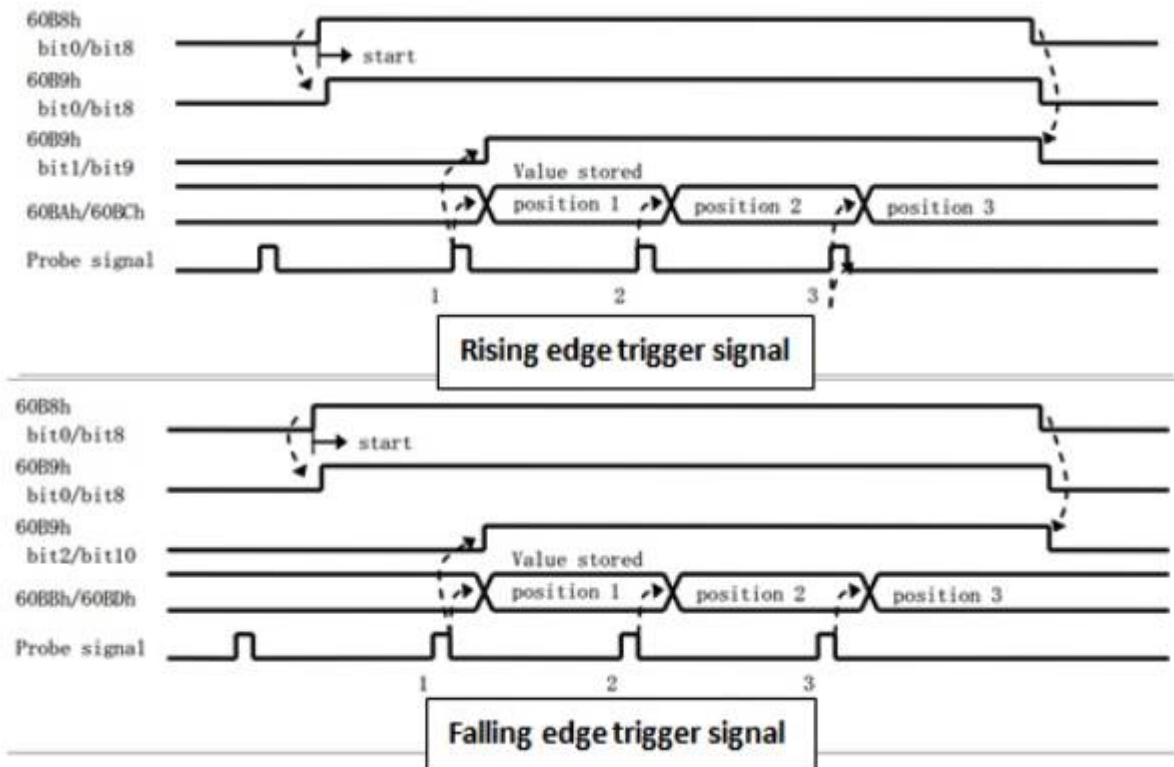

From:
<https://www.nilab.at/dokuwiki/> - NiLAB GmbH
Knowledgebase

Permanent link:
https://www.nilab.at/dokuwiki/doku.php?id=nl7_servo:probe_function

Last update: 2024/03/14 06:37

