

# Xtrapulspack Easy Servo Drive

In order to configure the drive to work with NiLAB, see this page:

[https://www.nilab.at/dokuwiki/doku.php?id=green\\_drive\\_motors:xtrapulspack](https://www.nilab.at/dokuwiki/doku.php?id=green_drive_motors:xtrapulspack)

Software per la parametrizzazione del drive:

<https://www.nilab.at/download/gemdrive-studio-5-36-infranor-drive/?wpdmdl=7376&refresh=67a1d90a4104f1738660106>

For control using CanOPEN fieldbus download the EDS here: [:miniature\\_motors:eds\\_file\\_easy-ak\\_v1.31.zip](#)

## Serial and CanOPEN communication - X5 connector pinout

Suggested USB to RS232 converter : [https://ftdichip.com/products/usb-rs232-we-1800-bt\\_0-0/](https://ftdichip.com/products/usb-rs232-we-1800-bt_0-0/)

SUB D 9 pin male connector

PIN	FUNCTION	REMARKS
1	Termination resistor	Connect X5.1 to X5.7 to enable the termination resistor
2	CAN-L	Line CAN-L (dominant low)
3	GND	GND signal for CAN communication
4	TXD	Transmit data RS-232
5	GND	GND (shield connection if no 360° connection on the connector). 360° shield connection is highly recommended.
6		Reserved
7	CAN-H	Line CAN-H (dominant high)
8	RXD	Receive data RS-232
9		Reserved

Default parameters for the CANopen bus are:

- Transmission speed of 1 Mb/s,
- Address set at 1,

## Motor and feedback connections

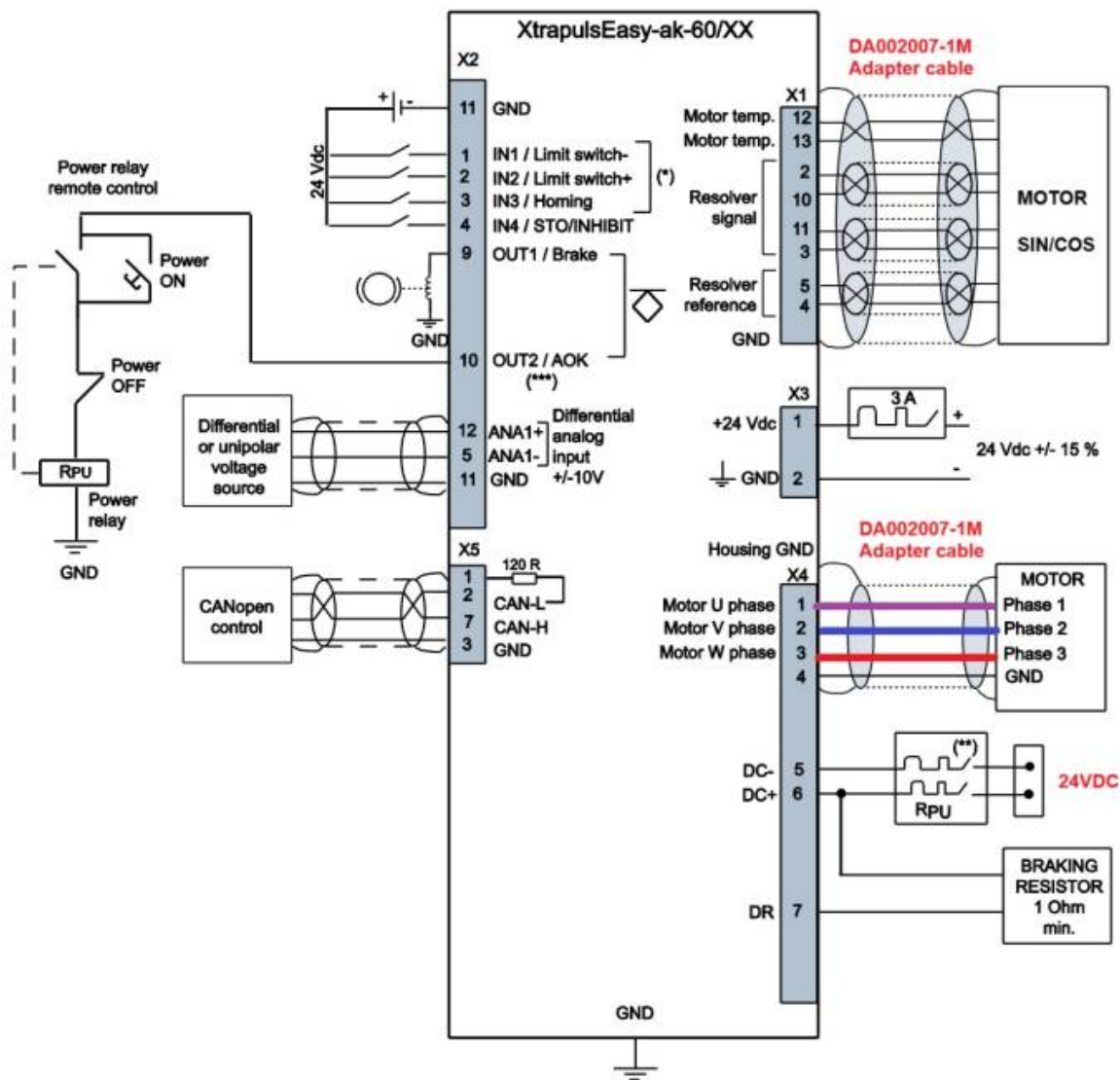

## Servo drive mechanical dimensions and connectors position



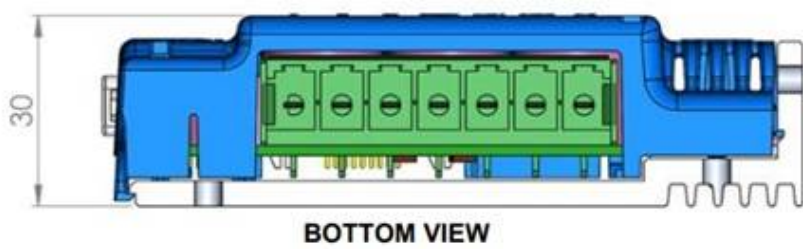

**BOTTOM VIEW**

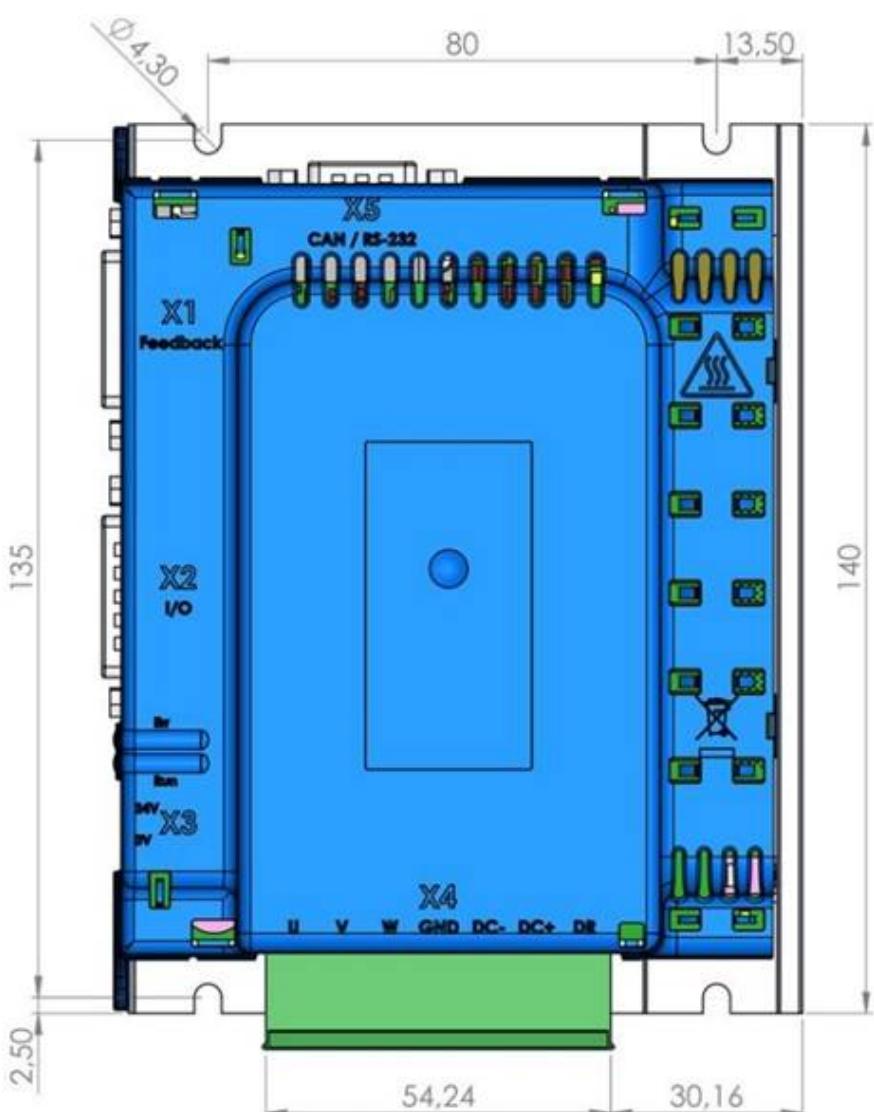

**SIDE VIEW**

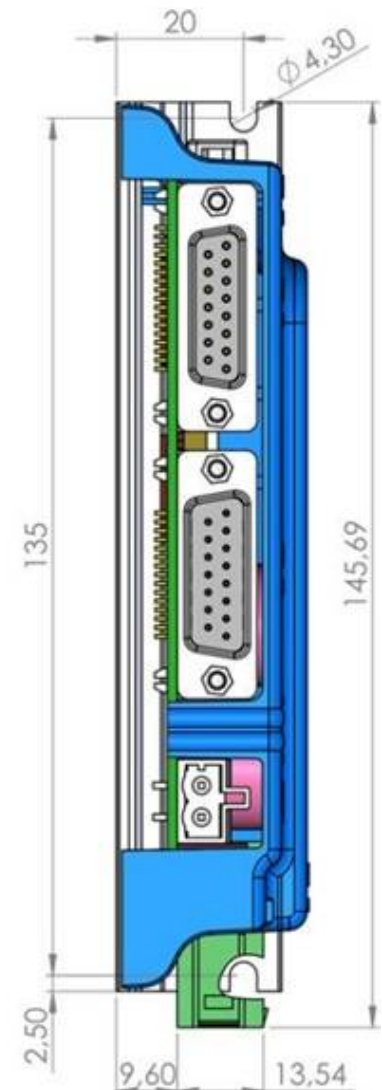

**FRONT VIEW**

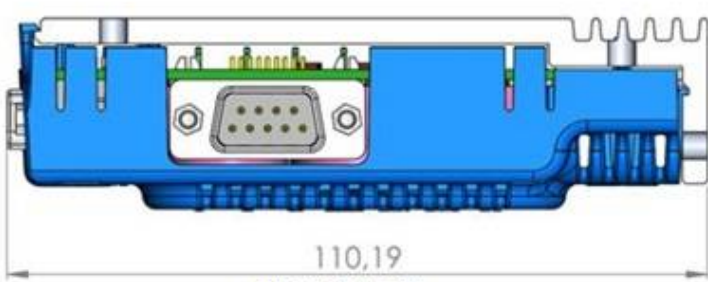

**RIPPER VIEW**

From:

<https://www.nilab.at/dokuwiki/> - **NiLAB GmbH**  
**Knowledgebase**

Permanent link:

[https://www.nilab.at/dokuwiki/doku.php?id=miniature\\_motors:xtrapulseasy](https://www.nilab.at/dokuwiki/doku.php?id=miniature_motors:xtrapulseasy)

Last update: **2025/03/19 14:37**

