

B&R Servo Drive

ACOPOS MULTI

Plug-in Module: **ENDAT 8BAC0120.000-1**

Figure	X11	Pin	Name	Function
		1	A	Channel A
		2	COM	Encoder supply 0 V
		3	B	Channel B
		4	+5V	Encoder supply +5 V
		5	D	Data input
		6	---	---
		7	T+	Temperature sensor +
		8	T	Clock output
		9	A\	Channel A inverted
		10	Sense COM	Sense input 0 V
		11	B\	Channel B inverted
		12	Sense +5V	Sense input +5 V
		13	D\	Data input inverted
		14	T-	Temperature sensor -
		15	T\	Clock output inverted

Table: Pin assignments - EnDat 2.1 interface 8BAC0120.000-1

Plug-in Module: **SIN/COS 8BAC0124.000-1**

Figure	X11	Pin	Name	Function
		1	A	Channel A
		2	COM	Encoder supply 0 V
		3	B	Channel B
		4	+5V	Encoder supply +5 V
		5	T+	Temperature sensor +
		6	Limit -	Negative limit (L2)
		7	R\	Reference pulse inverted
		8	Limit+	Positive limit (L1)
		9	A\	Channel A inverted
		10	Sense COM	Sense input 0 V
		11	B\	Channel B inverted
		12	Sense +5V	Sense input +5 V
		13	T-	Temperature sensor -
		14	R	Reference pulse
		15	---	---

Table: Pin assignments - SinCos interface 8BAC0124.000-1

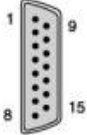
Acopos

Plug-in Module: **8AC120.60-1**

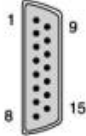
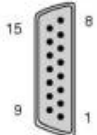

Figure	X11	Pin	Name	Function	
				EnDat mode	Incremental mode
		1	A	Channel A	
		2	COM (1, 3 - 9, 11, 13 - 15)	Encoder supply 0 V	
		3	B	Channel B	
		4	+5V out / 0.25A	Encoder supply +5 V	
		5	D	Data input	---
		6	---	---	
		7	R\	---	Reference pulse Inverted
		8	T	Clock output	---
		9	A\	Channel A inverted	
		10	Sense COM	Sense input 0 V	
		11	B\	Channel B inverted	
		12	Sense +5V	Sense input +5 V	
		13	D\	Data Inverted	---
		14	R	---	Reference pulse
		15	T\	Clock output Inverted	---

Table: Pin assignments for AC120 - EnDat Encoder Interface

Acopos P3

Plug-in Module: **8EAC0152.001-1**

Figure	X41M	Pin	Name	Function depending on configured encoder type			
				SinCos	EnDat 2.1	SSI SinCos	HIPERFACE
		1	B\	Channel B inverted			REF cosine
		2	B	Channel B			Cosine
		3	GND	Encoder power supply 0 V			
		4	A\	Channel A inverted			REF sine
		5	A	Channel A			Sine
		6	R	Reference pulse	Data +		
		7	R\	Reference pulse inverted	Data -		
		8	U+	Encoder power supply 5 V			Encoder power supply 12 V
		9	T-	Temperature sensor -	Clock -		Temperature sensor -
		10	T+	Temperature sensor +	Clock +		Temperature sensor +

Parametrization example

Motor : GD250XS

```
<Module Name="GD250XS_80_Nitek" Type="MotorSynchronous_any" Version="1.0.0.1">
  <Connection Connector="EC" TargetModule="8BAC0120.000-1c" TargetConnector="EC" />
  <Connection Connector="MT" TargetModule="8BVI0028HWS0.000-1a" TargetConnector="MT1" />
  <Parameter ID="MOTOR_WIND_CONNECT" Value="1" />
  <Parameter ID="MOTOR_POLEPAIRS" Value="1" />
  <Parameter ID="MOTOR_BRAKE_CURR_RATED" Value="0" />
  <Parameter ID="MOTOR_BRAKE_TORQ_RATED" Value="0" />
  <Parameter ID="MOTOR_BRAKE_ON_TIME" Value="0" />
  <Parameter ID="MOTOR_BRAKE_OFF_TIME" Value="0" />
  <Parameter ID="MOTOR_TEMPSSENS_PAR1" Value="0" />
  <Parameter ID="MOTOR_TEMPSSENS_PAR2" Value="0" />
  <Parameter ID="MOTOR_TEMPSSENS_PAR3" Value="0" />
  <Parameter ID="MOTOR_TEMPSSENS_PAR4" Value="0" />
  <Parameter ID="MOTOR_TEMPSSENS_PAR5" Value="0" />
  <Parameter ID="MOTOR_TEMPSSENS_PAR6" Value="0" />
  <Parameter ID="MOTOR_TEMPSSENS_PAR7" Value="0" />
  <Parameter ID="MOTOR_TEMPSSENS_PAR8" Value="0" />
  <Parameter ID="MOTOR_TEMPSSENS_PAR9" Value="0" />
  <Parameter ID="MOTOR_TEMPSSENS_PAR10" Value="0" />
  <Parameter ID="MOTOR_VOLTAGE_RATED" Value="400" />
  <Parameter ID="MOTOR_VOLTAGE_CONST" Value="32.39" />
  <Parameter ID="MOTOR_SPEED_RATED" Value="4000" />
  <Parameter ID="MOTOR_SPEED_MAX" Value="6000" />
  <Parameter ID="MOTOR_TORQ_STALL" Value="0.95" />
  <Parameter ID="MOTOR_TORQ_RATED" Value="0.95" />
  <Parameter ID="MOTOR_TORQ_MAX" Value="3.78" />
  <Parameter ID="MOTOR_TORQ_CONST" Value="0.497" />
  <Parameter ID="MOTOR_CURR_STALL" Value="1.9" />
  <Parameter ID="MOTOR_CURR_RATED" Value="1.9" />
  <Parameter ID="MOTOR_CURR_MAX" Value="7.6" />
  <Parameter ID="MOTOR_WIND_CROSS_SECT" Value="0.63" />
  <Parameter ID="MOTOR_STATOR_RESISTANCE" Value="10.6" />
  <Parameter ID="MOTOR_STATOR_INDUCTANCE" Value="0.0165" />
  <Parameter ID="MOTOR_INERTIA" Value="0.0001053" />
  <Parameter ID="MOTOR_COMMUT_OFFSET" Value="1.803" />
  <Parameter ID="MOTOR_TAU_THERM" Value="2694" />
  <Parameter ID="MOTOR_WIND_TEMP_MAX" Value="130" />
</Module>
```

Encoder configuration

Incremental encoder (nclNC) with **ParID 109** = 16384 (Interpolation factor)

Motor phases

V and W phase inverted.

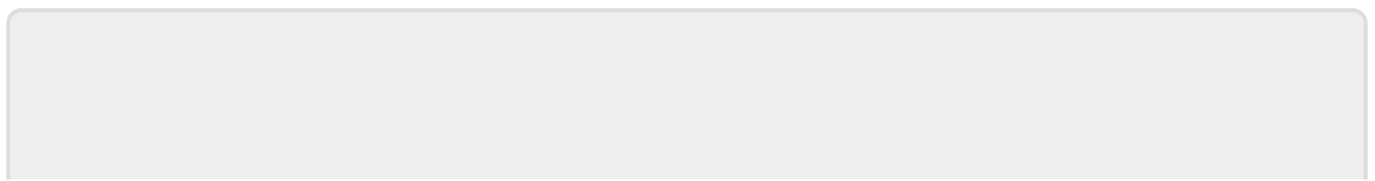

From:

<https://www.nilab.at/dokuwiki/> - **NiLAB GmbH**
Knowledgebase

Permanent link:

https://www.nilab.at/dokuwiki/doku.php?id=green_drive_motors:servo_b_r



Last update: **2026/02/10 15:45**