

# Inputs and outputs connection

In Epulse50 are available 2 programmable digital inputs, 2 analog inputs, CanOPEN for communication and an interlock safety input.

In order to use the CanOPEN termination, please make a connection (jumper) between pin 1 and pin 9.

I/O CONNECTOR C2		
PIN	NOME	DESCRIZIONE
1	CAN-TERM	CAN L termination resistance 120 Ohm
2	CANL	CAN-Low
3	CAN_GND	CAN-GND / board GND
4	DGT-IN2	Digital input 2, 24V - PROGRAMMABLE
5	DGT_OUT_2	Digital output 2
6	DGT_OUT_VCC	Digital output Vcc
7	DGT_OUT_1	Digital output 1
8	AGND GROUND	Analog ground of AGND-IN1 and 2. Connect to GND of ext. controller
9	CAN-TERM	CAN H termination resistance 120 Ohm
10	CANH	CAN-High
11	ANALOG-IN1	Analog input 1, 0-10V - PROGRAMMABLE
12	ANALOG-IN2	Analog input 2, 0-10V - PROGRAMMABLE
13	DGT-IN1	Digital input 1, 24V - PROGRAMMABLE
14	5V	Otput supply 5V@200mA
15	DGT-OUT-GND	Digital output GND
16	CONTROL SUPPLY	Control board power supply, supply with a voltage from 10V to 80V

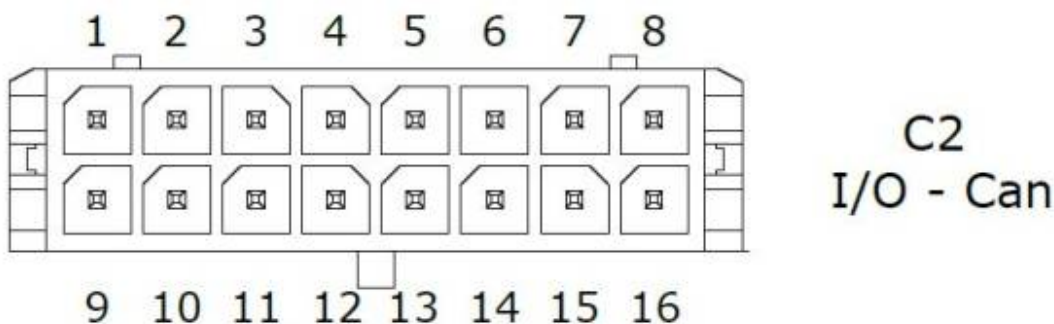

Port	Ordering Code	Brand	Description
C2	43025-1600	Molex	16 poles male, for input/output/can (Receptacle Housing)

## Outputs electrical charateristics

Paramter	Epulse30	Epulse50	Epulse 100	Unit
Output type	open collector NPN	open collector NPN	open collector NPN	-
Output current	0,5	2	2	A

Pulse peak current	1,0	4	4	A
Control input current	30mA @ 24VDC	30mA @ 24VDC	30mA@24VDC	-

## Output signal schematics

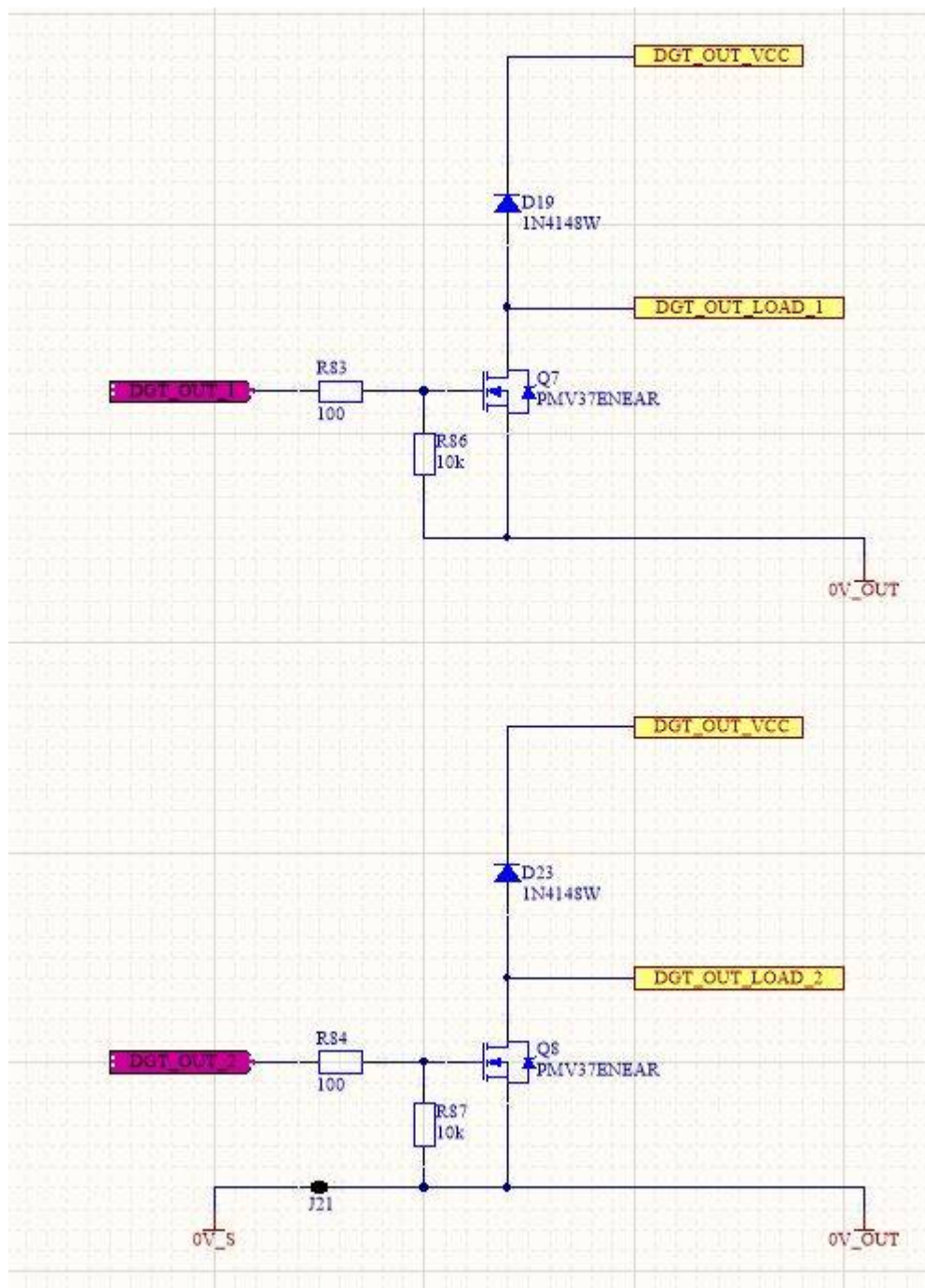

From:  
<https://www.nilab.at/dokuwiki/> - NiLAB GmbH  
Knowledgebase

Permanent link:  
[https://www.nilab.at/dokuwiki/doku.php?id=epulse50\\_dc\\_servodrive:io\\_connector](https://www.nilab.at/dokuwiki/doku.php?id=epulse50_dc_servodrive:io_connector)

Last update: 2024/10/28 09:18



